

Etanorm - Standardised Water Pump

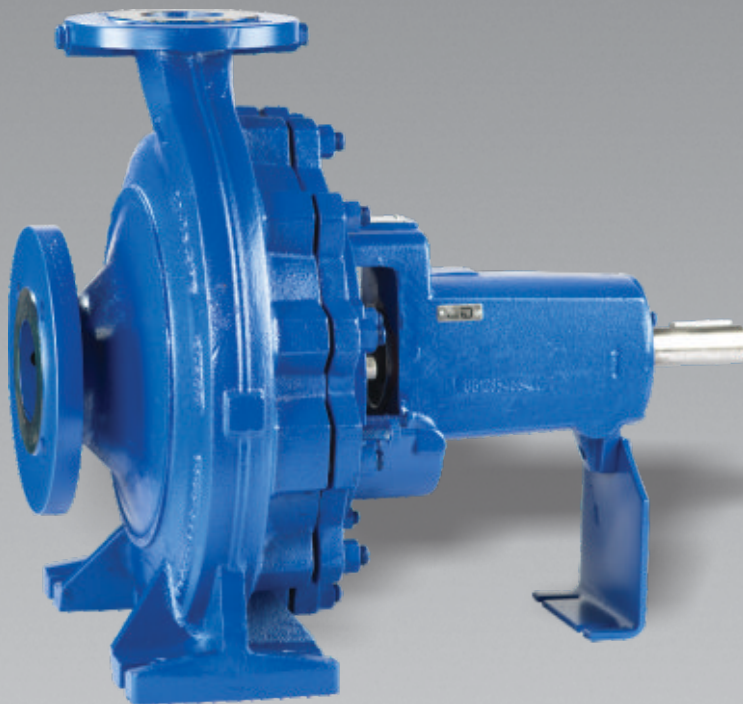

Applications :

Pure liquids not chemically or mechanically aggressive to the pump materials.

- Water supply
- Cooling water
- Swimming pool water
- Fire-fighting systems/ water
- Spray irrigation
- Irrigation
- Service water
- Cleaning agents
- Drinking water
- Drainage
- Condensate
- Heating, air-conditioning
- Hot water

Etanorm - Standardised Water Pump

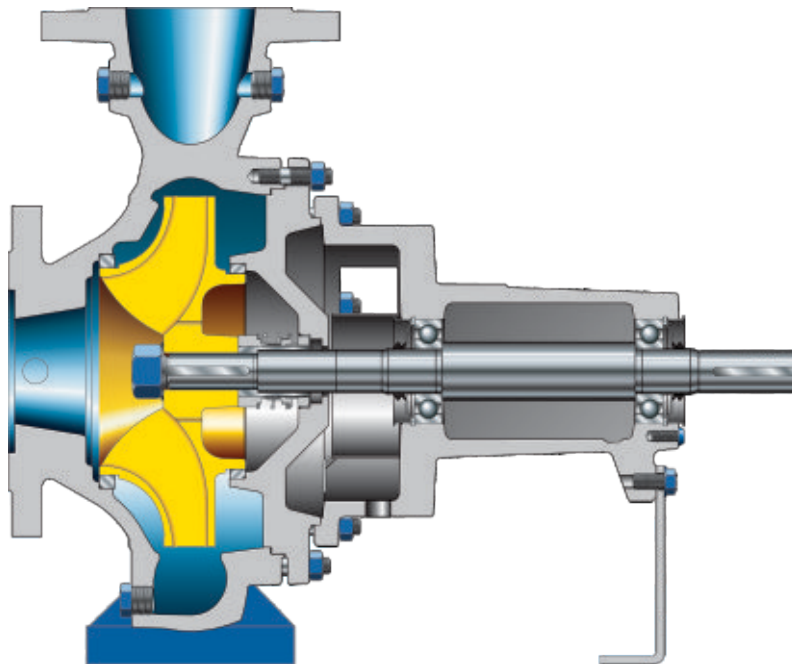

■ Low energy consumption

Optimised and tested hydraulic system of high efficiency. As a standard, the impellers are trimmed to the operating point.

■ High energy efficiency

Meets the European requirements for energy-efficient operation of water pumps with a minimum efficiency index $MEI \geq 0.4$.

■ Operating reliability

Good suction performance for low vibration levels and very smooth running.

■ Versatile

Great choice of materials for many applications available as a standard.

■ Diversity of variants

Additional sizes for small flow rates extend the already diverse range of selection charts.

■ Service-friendly

Fast delivery of new pumps and spare parts. Easier to assemble and dismantle thanks to the larger seal chamber and forcing screws between the casing cover and bearing bracket.

Technical data

Pump size	DN 25 to 150 mm
Flow rate	Up to 660 m ³ /h (50Hz) Up to 780 m ³ /h (60Hz)
Head	Up to 160 m (50Hz) Up to 160 m (60Hz)
Fluid temperature	-30 °C to +140 °C
Pressure	up to 16 bar

Material variants

Grey cast iron A 48 CL 35B
Stainless steel A743 Gr CF8 M
Bronze CC480K-G5 / LTB2



KSB Pumps Limited

Mumbai-Pune Road, Pimpri, Pune - 411 018. India.
Tel.: +91 20 2710 1000 Fax : +91 20 2742 6000 www.ksbindia.co.in